



**Van Borselen**  
FILTERS



## **BorsoNylo**

Nylon 6.6 Membrane Cartridge Filters

# BorsoNylo

## Nylon 6.6 Membrane Cartridge Filters

**A range of microbially rated cartridge filters from Van Borselen Filters, featuring the latest developments in membrane technology, BorsoNylo cartridges are based on a naturally hydrophilic nylon membrane. When combined with quality all-polypropylene cartridge components and high integrity manufacturing techniques common to all Van Borselen Filters, the nylon membrane provides a high strength, long life cartridge of consistently precise particle retention across a wide range of particle sizes.**

BorsoNylo cartridges exploit the narrow pore size distribution and high void volume of the media to provide a choice of cartridges capable of meeting the requirements of most applications. Careful media selection ensures that BorsoNylo cartridges are also very suited to critical particle control down to 0.03 micron ratings. BorsoNylo cartridges offer high flux rates and low differential pressures, a feature common to nylon membranes. BorsoNylo cartridges benefit from high protein binding characteristics of nylon membranes. They are also highly resistant to integrity failure caused by steam sterilisation and have excellent chemical compatibility characteristics. BorsoNylo cartridges are ideal for use in ultra pure water supply systems (18M $\Omega$ .cm)

As a consequence BorsoNylo cartridges provide a combination of features and benefits not hitherto available from cartridges based on PVDF, mixed esters of cellulose or polysulphone membranes. They are suitable for applications ranging from sterile filtration, bioburden reduction and the clarification of a wide range of process liquids and end products.

## Applications

BorsoNylo cartridges are suitable for the sub-micronic filtration of a wide range of process liquids, in applications where the characteristics of a naturally hydrophilic membrane are required.

### Typical applications include:

#### Biopharmaceuticals

For the sub-micronic filtration of ingredients, intermediates, make-up waters and final products, including sterilisation, clarification and bioburden reduction.

#### Electronics and semiconductors

For the sub-micronic filtration of process water and chemicals, including solvents, developers and photoresists. Applications typically include central water plant treatment & critical 'wet bench' point of use filtration.

#### Fine chemicals

For the clarification and sterilisation of a wide range of process chemicals.

#### Beverages

For the clarification and sterilisation of various beverages, including the removal of yeast and spoilage organisms.

#### Pure water supply

For use in ultrapure water treatment systems (including Water-For-Injection), as either a sterilisation filter or for bioburden reduction.



## Features and Benefits



### BorsoNylo cartridges

Careful media selection means that BorsoNylo cartridges are available to suit a wide range of process critical and general purpose applications.



### Guaranteed microbial rating

BorsoNylo cartridges are validated for bacterial removal according to HIMA guidelines and ASTM F838-05, with a log reduction value >7. They are therefore suitable for applications requiring sterilising grade filtration.



### Excellent chemical compatibility

Resistant to many process chemicals, BorsoNylo cartridges are suitable for use in a wide range of process applications.



### Cartridge integrity and low TOC levels

BorsoNylo module of every cartridge is individually integrity tested. Each complete filter cartridge is flushed with pure water which is inspected daily for pyrogens using the standard LAL test. When required, they can be pulse flushed with 18MΩ.cm pyrogen-free ultra-clean water.



### Suitable for steam sterilising

BorsoNylo cartridges incorporating a stainless steel support ring can be subjected to steam sterilisation at 125°C (257°F) without loss of integrity.



### Full traceability

All BorsoNylo cartridges are individually and batch identified with a unique serial number. BorsoNylo cartridge is supplied with a Certificate of Quality and an operating instruction leaflet.



### Controlled manufacturing environment

BorsoNylo cartridges are manufactured in an ISO Cleanroom environment by fully gowned staff, minimising the risk of contamination

## Cartridge Construction

BorsoNylo cartridges are manufactured from a multi-layer combination of irrigation mesh, filter membrane, membrane support and drainage material. BorsoNylo cartridges have optimal pleat geometry to maximise the available filtration area and to ensure an efficient flow through the cartridges. An all thermal fusion bonded assembly process eliminates the use of resins and binders.

Manufactured as standard with injection moulded polypropylene inner and outer supports, BorsoNylo cartridges are designed with the strength necessary to withstand thermal stresses encountered during steam sterilisation and subsequent cooling. They can be steam sterilised and will retain total integrity following steaming at 125°C (257°F). All components used in the construction of BorsoNylo cartridges are FDA approved to 21CFR and meet or exceed the latest EC Directives for Food Contact.

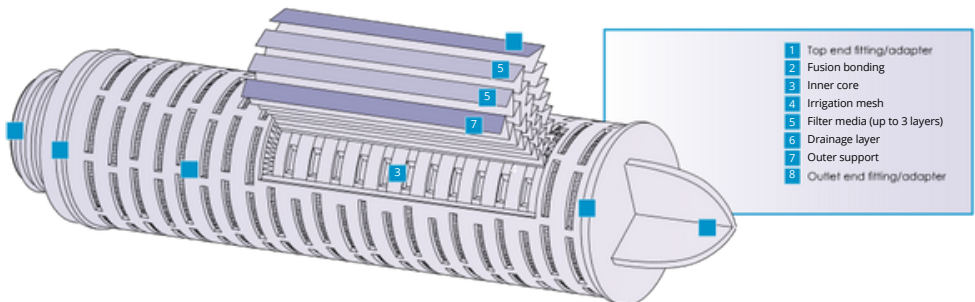

# Specification

## Materials of Manufacture

|                           |   |                 |
|---------------------------|---|-----------------|
| Filter membrane           | : | Nylon 6,6       |
| Membrane support          | : | Polypropylene   |
| Irrigation mesh (support) | : | Polypropylene   |
| Drainage layer:           | : | Polypropylene   |
| Inner core                | : | Polypropylene   |
| Outer support             | : | Polypropylene   |
| End fittings              | : | Polypropylene   |
| Support ring              | : | Stainless Steel |

## Cartridge Dimensions (Nominal)

|          |             |               |
|----------|-------------|---------------|
| Diameter | 70mm (2.8") |               |
| Length   | 1 module    | :127mm (5")   |
|          | 1 module    | :254mm (10"), |
|          | 2 modules   | :508mm (20")  |
|          | 3 modules   | :762mm (30"), |
|          | 4 modules   | :1016mm (40") |

## Effective Filtration Area

| Absolute Microbial Rating (in liquids) | Effective Filtration Area (each 254mm (10") module) |
|--|---|
| 0.03, 0.1, 0.2 and 0.45µm              | 0.69m <sup>2</sup> (7.4ft <sup>2</sup> )            |

## Cartridge Treatment

|          |   |
|----------|---|
| Standard | : Cleaned and flushed with pyrogen-free water.                        |
| Rinsed   | : Ultra-clean, pulse flushed to give a system resistivity of 18MΩ.cm. |

## Gaskets and O-Rings

Ethylene Propylene, FEP encapsulated, Silicone, Viton® or Nitrile.

## Maximum Differential Pressure

### Normal flow direction at :

|               |                 |
|---------------|-----------------|
| 20°C (68°F)   | :6.0bar (87psi) |
| 80°C (176°F)  | :4.0bar (58psi) |
| 100°C (212°F) | :3.0bar (44psi) |
| 120°C (248°F) | :2.0bar (29psi) |

### Reverse flow direction at :

|               |                 |
|---------------|-----------------|
| 20°C (68°F)   | :2.1bar (30psi) |
| 80°C (176°F)  | :1.0bar (15psi) |
| 100°C (212°F) | :0.5bar (7psi)  |

## Operating Temperature

Maximum continuous :60°C (140°F)

## Sterilisation

*In situ* steam 30 x 25 minute cycles at 125°C (257°F).

## Extractables

Minimum total extractables. Please refer to the BorsoNylo Validation Guide.

## Integrity Testing

Each BorsoNylo module of every cartridge is individually integrity tested using the Diffusive Flow Test, which correlates to the HIMA and ASTM F838-05 bacterial challenge tests. Non-destructive integrity tests, such as Pressure Hold, Diffusive Flow and Bubble Point, can be performed by customers. Procedural details are available from Van Borselen Filters.

## Clean Water Flow Rates

Typical clean water flow rate: A 254mm (10") BorsoNylo single cartridge exhibits the flow-ΔP characteristics indicated below, for solutions with a viscosity of 1 centipoise.

Other solutions:

For solutions with a viscosity of greater than 1 centipoise, multiply the indicated differential pressure by the viscosity in centipoise.

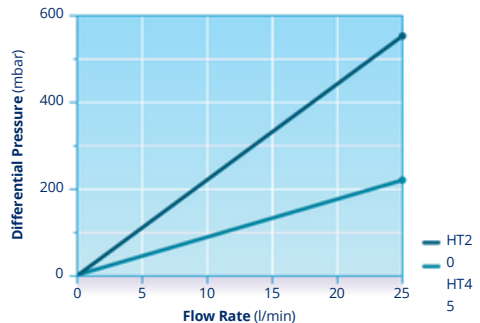

## Additional Information

### Range

Suitable for use in Van Borselen Filters and as direct replacements for existing cartridges, BorsoNylo cartridges can be supplied with end fittings to suit most hardware installations without modification. They are available in single or multiple module units of 5, 10, 20, 30 and 40 inches, and in a choice of four microbial ratings: 0.03, 0.1, 0.2 and 0.45 micron. Each cartridge is supplied with all necessary seals or O-rings to ensure chemical compatibility.

### Quality Assurance

BorsoNylo cartridges are manufactured in an ISO Cleanroom environment by staff fully gowned to minimise any risk of contamination during production. All cartridges are integrity tested and, if required, pulse flushed with 18M $\Omega$ .cm pyrogen-free ultra-pure water to give rapid resistivity recovery rates and low TOC levels. As a further safeguard, every cartridge is individually and batch identified with a unique serial number, allowing users to maintain their own process records.

Registered to ISO 9001, Van Borselen Filters procedures are subject to high standards of quality assurance as demonstrated through its Drug Master File status.

### Material Conformity and Validation

The bio-safety of all materials in the manufacture of BorsoNylo cartridges is assured by FDA approval, USP Class VI and meets or exceeds the latest EC Directives for Food Contact.

BorsoNylo cartridges have been tested and shown to be 100% retentive in line with HIMA and ASTM F838-05 guidelines for *Brevundimonas diminuta* challenge (0.2 micron) and *Serratia marcescens* (0.45 micron). To guarantee the bacterial retention performance of every cartridge, a correlation has been made between the bacterial challenge and integrity tests. A comprehensive validation guide for BorsoNylo cartridges is available on request.

### Chemical Compatibility

The BorsoNylo materials of construction are compatible with a wide range of chemicals and solvents, however care must be taken to select the appropriate seal material. A comprehensive chemical compatibility guide is available. Since operating conditions vary considerably between applications, verification by the end user is recommended.

### Filter Housings

Please contact a **Van Borselen Filters** representative for further information on our range of filter housings.

# VAN BORSELEN FILTERS



## ABOUT US

With over 100 years of experience, we have developed deep expertise in filtration and separation. Van Borselen Filters is located in The Netherlands, where an enthusiastic team of filtration and separation specialists is dedicated to serving our clients.



**100 years of  
experience**



**Excellent  
service**



**High-standard  
products**

